

GOTSCHLICH

Ecco 120 BD

The motor-driven man-height twin portal turnstile Ecco 120 HD with drum, deflection rack, guiding elements and stands in stainless steel is particularly suitable for outdoor plant security applications, as well as sports arenas, leisure facilities and pedestrian connections between car parks and office or residential buildings.

Control electronics are situated maintenance-friendly in the central cabinet, which also offers room for mounting card readers, intercoms and other appliances.

Ecco 120 HD is suited for unidirectional or bidirectional operation. With its 120° pitch, it offers high pedestrian comfort and good separating.

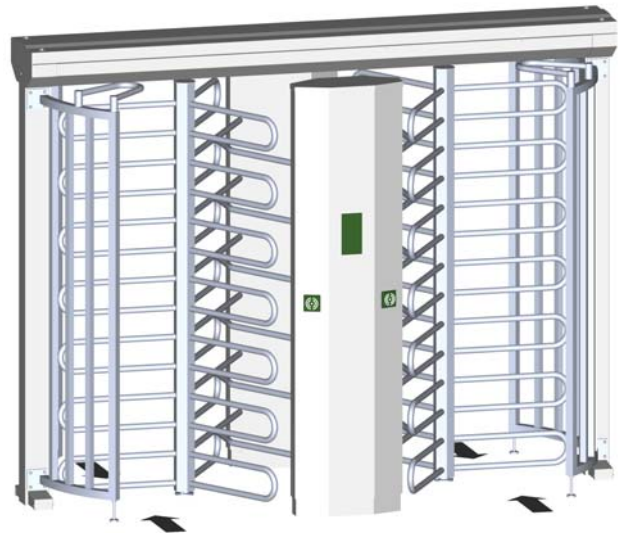

Features

- Card Readers Integrable
- Simple Mounting
- Vandalism Resistant
- Uni- or Bidirectional Operation
- Selectable Entrance Direction
- High Durability
- Integrated Electronic Control
- Maintenance-free Mechanism
- Highly Accessible Electronics
- Transition Counts

Application Areas

- Plant Security
- Sports and Leisure Facilities
- Car Parks

Models/Options

- Twin portal turnstile with bails, 120° pitch, stainless steel

Options:

- Roofing with optional Eaves gutter and lighting
- Blocked at power-down



Technical Characteristics

Power Supply:	230 V AC 50-60 Hz
Power Consumption:	50 VA max.
Operating Temperature:	-25°C to +40°C
Outer/Inner Width:	2.901 mm/640 mm
Length:	1.300 mm
Height:	2.252 mm
Weight:	230 kg
Reader Interface:	Floating Contacts
Material:	CrNi-Steel Type 1.4301 Aluminium, powder-coated

Functional Description

In normal operation, an electric brake holds the drum in its blocking position.

Upon reception of a release signal from the reader system or an optional external manual control, the brake is released, allowing turning the drum in the preset direction.

Application of slight pressure triggers the driving motor, which turns the drum by 120°. Internal sensors prevent injuries from the turning bars running against the backs of passing pedestrians.

After completion of the transit, the turnstile sends a signal to the reader.

Powered off, the turnstile arms can be turned manually with little force.

The 120° pitch ensures high comfort and good separating of persons.

The design prevents climbing over the turnstile.

Standards

CE	Directive of Machinery 98/37/ec
UL	94 V-0
VDE/ÖVE	protective earthing
Protection Class:	IP 43 / EN 60529
Production Standard:	ISO 9001

Application Example (Plan View)

Dimension Overview

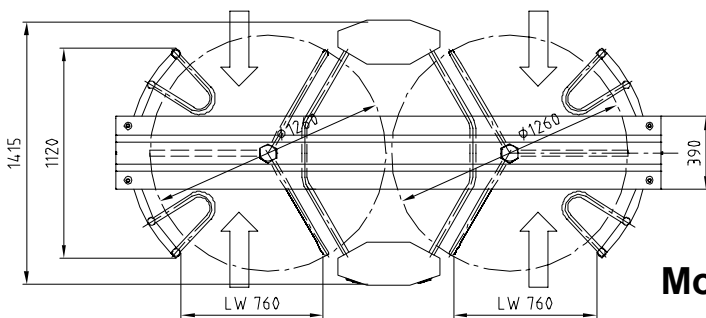
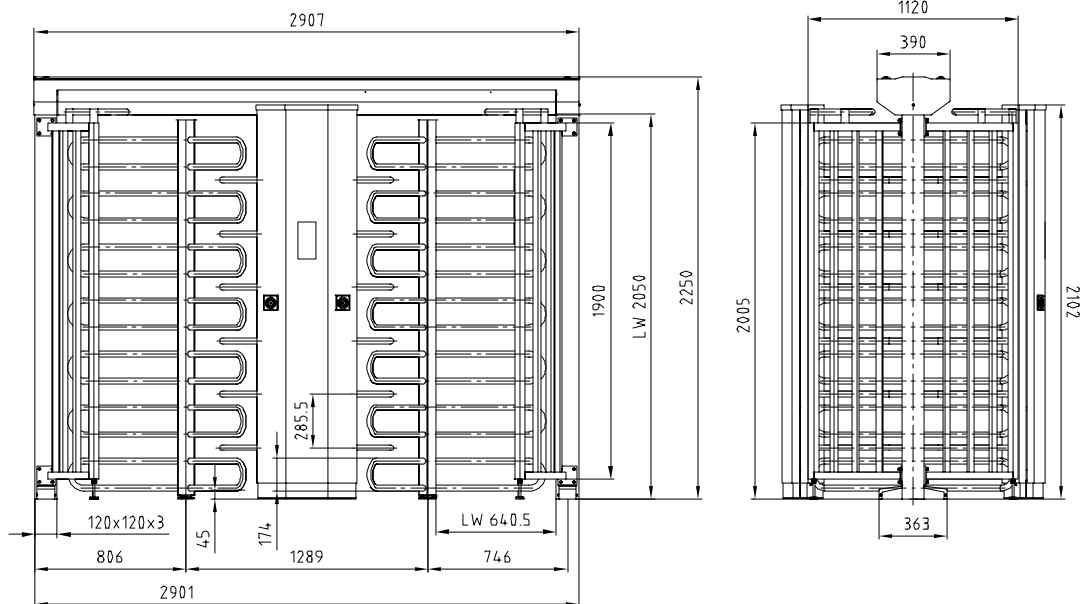

Models:

62212: Ecco 120 BD INOX

Electrical Ports

Input:

- Reader Release Entrance Direction
- Reader Release Exit Direction
- Manual Release Entrance Direction
- Manual Release Exit Direction
- Permanent Release Entrance Direction
- Permanent Release Exit Direction
- Stop Button

Output:

- External Counter non-resettable Entrance
- External Counter non-resettable Exit
- External Light
- Feedback

Extras & Options:

- Foundation Assembly with Template
- Reader Mounting Fee
- Roof 1,300 mm length
- Eaves gutter for roof
- Inner ceiling with lighting

61950: External console

22000: Blocked at power-down

Suitable By-Products:

62202: Ecco 120 BB Single Turnstile



Sample Tender Document Entry

Pos.	Qty.	Text	Unit Price	Total
		<p>pcs. twin vertical turnstile(s), man-high, with motor-driven turnstile drum. Blocking device bails with 120° pitch.</p> <p>Blocking device, deflection rack, guiding element and stand in V2A stainless steel, matt finished or sanded and coated with acid protection. Bridge hot-galvanized steel, plastic coated.</p> <p>Gearbox cover Aluminium powder-coated RAL 9006 White Aluminium.</p> <p>Maintenance-free drive</p> <p>Power supply and electronic control for bidirectional operation integrated in the turnstile. Drive mounted overhead, electronics easily accessible in central cabinet</p> <p>230 V AC 50 Hz operation</p> <p>Prepared for physical and electrical integration of card readers or biometric access control devices on both sides.</p> <p>Screw mounting, direct on sustainable floors (e.g. concrete foundation) or with optionally available mounting brackets on non-sustainable floors.</p> <p>Reference product: Gotschlich Ecco 120 BD</p> <p>with the following accessories:</p> <p><input type="checkbox"/> External console for manual operation</p>		